

Display driver module

32 SPI-driven displays

Schematic

The concept is to buffer the time-critical clock signal. A wire connected directly to the MCU is loaded by the long distance (resistance in the connectors and wires) and could be susceptible to noise. Using a 541 buffer and shunt resistors controls this impedance. The serial data and data/command (DC) signals are also buffered to avoid time propagation errors.

The second purpose is to use a chain of shift registers to provide chip select (CS) signals. It is functionally equivalent to a DOUT module, but the header is directly compatible with GPIO on the Core.

The pinout for the display connectors is as follows:

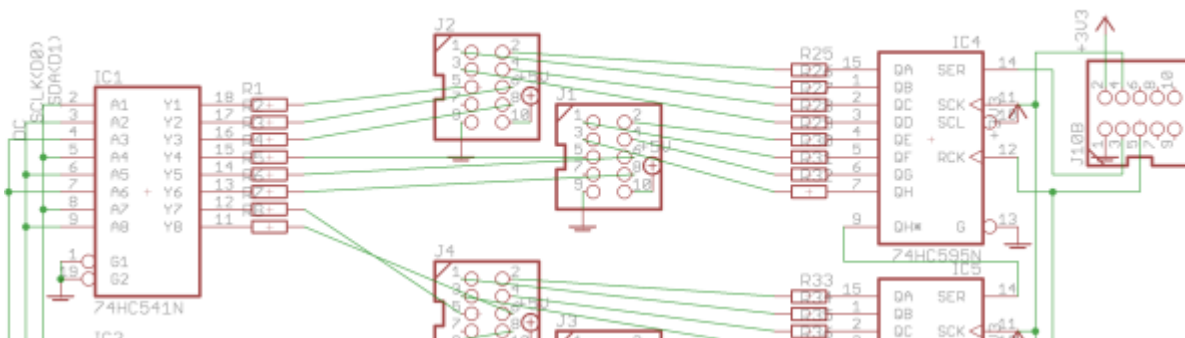

(Power is connected to pin 10.)

BOM v1.0

Type	Part	Value	Device
Caps	C1	100n	C025-025×050
	C2	100n	C025-025×050
	C3	100n	C025-025×050
	C4	100n	C025-025×050
	C5	100n	C025-025×050
	C6	100n	C025-025×050
	C7	100n	C025-025×050
ICs	IC1	74HC541N	74HC541N
	IC2	74HC541N	74HC541N
	IC3	74HC541N	74HC541N
	IC4	74HC595N	74HC595N
	IC5	74HC595N	74HC595N

Type	Part	Value	Device
	IC6	74HC595N	74HC595N
	IC7	74HC595N	74HC595N
Headers	J1	PINHD-2X54WALL	PAK100/2500-10
	J2	PINHD-2X54WALL	PAK100/2500-10
	J3	PINHD-2X54WALL	PAK100/2500-10
	J4	PINHD-2X54WALL	PAK100/2500-10
	J5	PINHD-2X54WALL	PAK100/2500-10
	J6	PINHD-2X54WALL	PAK100/2500-10
	J7	PINHD-2X54WALL	PAK100/2500-10
	J8	PINHD-2X54WALL	PAK100/2500-10
	J9	+5V	22-23-2031
	J10B	PINHD-2X54WALL	PAK100/2500-10
	J10B1	PINHD-2X54WALL	PAK100/2500-10
	J15A	PINHD-2X8THTTHT	PAK100/2500-16
	J15A1	PINHD-2X8THTTHT	PAK100/2500-16
Resistors	R1	~220R	0207/10
	R2	~220R	0207/10
	R3	~220R	0207/10
	R4	~220R	0207/10
	R5	~220R	0207/10
	R6	~220R	0207/10
	R7	~220R	0207/10
	R8	~220R	0207/10
	R9	~220R	0207/10
	R10	~220R	0207/10
	R11	~220R	0207/10
	R12	~220R	0207/10
	R13	~220R	0207/10
	R14	~220R	0207/10
	R15	~220R	0207/10
	R16	~220R	0207/10
	R17	~220R	0207/10
	R18	~220R	0207/10
	R19	~220R	0207/10
	R20	~220R	0207/10
	R21	~220R	0207/10
	R22	~220R	0207/10
	R23	~220R	0207/10
	R24	~220R	0207/10
	R25	~1k	0207/10
	R26	~1k	0207/10
	R27	~1k	0207/10
	R28	~1k	0207/10
	R29	~1k	0207/10
	R30	~1k	0207/10

Type	Part	Value	Device
	R31	~1k	0207/10
	R32	~1k	0207/10
	R33	~1k	0207/10
	R34	~1k	0207/10
	R35	~1k	0207/10
	R36	~1k	0207/10
	R37	~1k	0207/10
	R38	~1k	0207/10
	R39	~1k	0207/10
	R40	~1k	0207/10
	R41	~1k	0207/10
	R42	~1k	0207/10
	R43	~1k	0207/10
	R44	~1k	0207/10
	R45	~1k	0207/10
	R46	~1k	0207/10
	R47	~1k	0207/10
	R48	~1k	0207/10
	R49	~1k	0207/10
	R50	~1k	0207/10
	R51	~1k	0207/10
	R52	~1k	0207/10
	R53	~1k	0207/10
	R54	~1k	0207/10
	R55	~1k	0207/10
	R56	~1k	0207/10

Versions

v1.0: first release. Erratum: there is a significant error in that J15 is mirrored. The simplest way to get it working is to swap pairs of the ribbon wires as shown:



Here the header notches are aligned with the silkscreen. Only the first six wires are required.

Assembly

All parts are THT, start with resistors and caps, IC sockets then headers.

Interconnection to Core

J10B connects to J10B. J15A to J15A. Note the mirrored connection on v1.0

J15A1/J10B1 chain another Display Driver. Note that the J15 connection should not be mirrored for subsequent boards.

Dimensions

The PCB is 100*100mm with 3.2mm diameter holes centred 3.5mm from the edges.

License

Currently the design is © 2018 antilog devices with all rights reserved; all documentation is CC BY-NC-SA 3.0.

From:

<https://midibox.org/dokuwiki/> - **MIDIbox**

Permanent link:

https://midibox.org/dokuwiki/doku.php?id=display_driver&rev=1522503373

Last update: **2018/03/31 13:36**

