

Envelope Follower

based on Harry Bissel
a SMD Variant, ready for Pick and Place

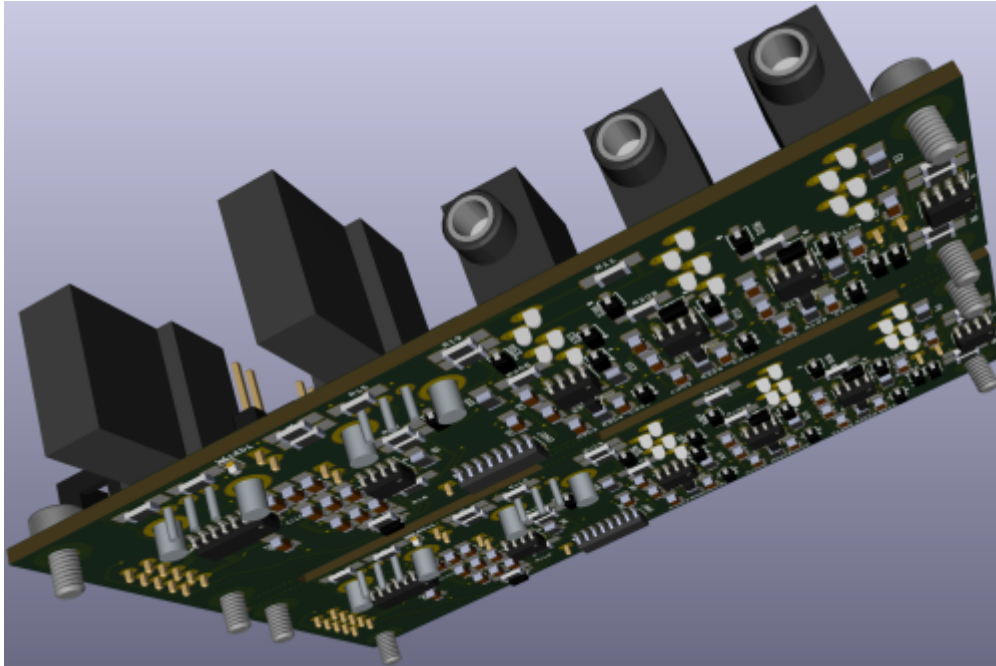

-shown 2 identical boards on one pcb - to save money..

Features

- * audio in * Envelope out * Gate out + Gate Threshold-Poti
- * Full-wave rectifier
- * 3 identical Peakdetectors which are Reseted from a "stepper"
- * a Oscillator with tunable Frequency to drive the stepper
- * Smoothingcap set via Jumper
- * Debugging Jumpers
- * PTC and Diode Polarity Protection on the Supply-side

Hardware Requirements

- This Device i build as input module for my [CV1](#) Project, but can be used for other things too
- Soldering Iron - with a Dip that can Handle SMD-Parts, Wires, solder Paste...
- Eurorack Power Source +-12V!

Building

The Design is optimized for Pick and Place most SMD Parts are on the Top-PCB

i ordered 5 PCBs from JLCPCB with almost all SMD Parts presoldered(except 2 SOIC chips PTC and Protection Diode)

now waiting for Presoldered PCBs

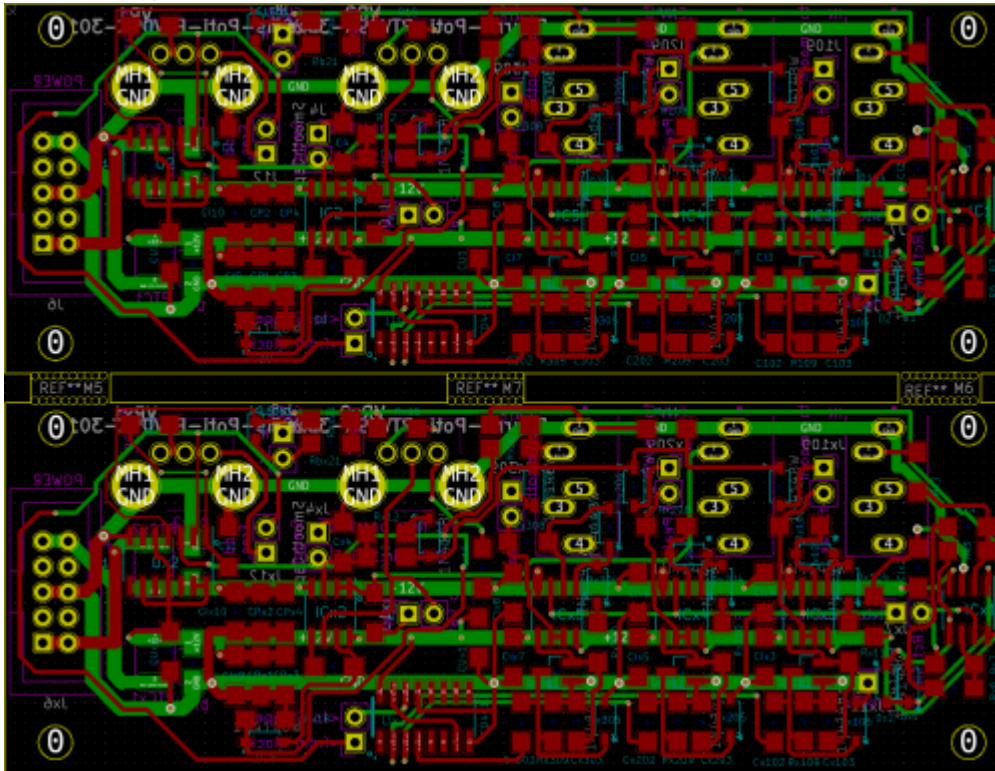

Frontpanel



- Eurorack Alu-Plate

BOM LCSC

these are the parts which are presoldered by the Pick and Place Machine, these are “Basic” Parts the values with a “x” in it, like Dx1 — are because there are 2 Identical Parts on 1 PCB, because there 2PCBs on 1PCB.... so Dx1 is the same like D1, but its position is on the second board.

Value	Designator	Footprint	LCSC Part Number	Library-Type
100nF	C1,CU1,C11,C1x1,CUx1,Cx1,CU2,C12,C1x2,CUX2,CP3,C13,C1x3,CPx3,CP4,C14,C1x4,CPx4,C4,Cx4,C15,C1x5,C16,C1x6,C17,C1x7,C18,C1x8,C19,C1x9,C110,C1x10	1206	C24497	
1nF	C102,Cx102,C103,Cx103,C202,Cx202,C203,Cx203,C302,Cx302,C303,Cx303	1206	C35216	
47uF	CP1,CPx1,CP2,CPx2	1206	C96123	
1N4148W	D1,Dx1,D2,Dx2,D7,Dx7,D8,Dx8,D103,Dx103,D104,Dx104,D105,Dx105,D106,Dx106,D203,Dx203,D204,Dx204,D205,Dx205,D206,Dx206,D303,Dx303,D304,Dx304,D305,Dx305,D306,Dx306	SOD123	C81598	
TL072	IC1,ICx1,IC2,ICx2,IC3,ICx3,IC4,ICx4,IC5,ICx5	SOIC-8	C6961	
2N3904	Q101,Qx101,Q201,Qx201,Q301,Qx301	SOT-23	C20526	
100K	R12,Rx12,R13,Rx13,R17,Rx17,R18,Rx18,R108,Rx108,R110,Rx110,R208,Rx208,R210,Rx210,R308,Rx308,R310,Rx310	1206	C17900	
1K	R1,Rx1,R8,Rx8,R11,Rx11,R20,Rx20,Ra21,Rax21	1206	C4410	
2K	R19,Rx19	1206	C17944	
10K	R3,Rx3,R4,Rx4,R5,Rx5,R6,Rx6,R7,Rx7,R15,Rx15,R16,Rx16,R109,Rx109,R209,Rx209,R309,Rx309	1206	C17902	
220	Rb21,Rbx21	1206	C17958	

when making 10Boards...a total of **42,44€** presoldered on the PCBsincl Shipping and Import-Taxes

BOM Mouser

These are the parts which has to be handsoldered

[copy list below](#), and paste in this link, you will need to order the project 2 times since 2PCBs are on 1PCB

583-FM4002|2

490-SJ1-3535NG-GR|3

523-G821EU210AAL10Y|1

650-MINISMDC014F-2|2

771-HEF40106BTD-T|1

595-CD4017BM|1

652-PTV09A-3015FB103|1

652-PTV09A3020FB104|1

for prototyping i ordered:

490-SJ1-3535NG-GR instead of **490-SJ1-3535NG** because it is out of stock - so **GREEN sockets** for now!

when making 10PCBs this make a total of **69,83€** incl Shipping/VAT which is free above 50€!

There are 2 SOICs that have to get Handsoldered, i have done this before and its easy!

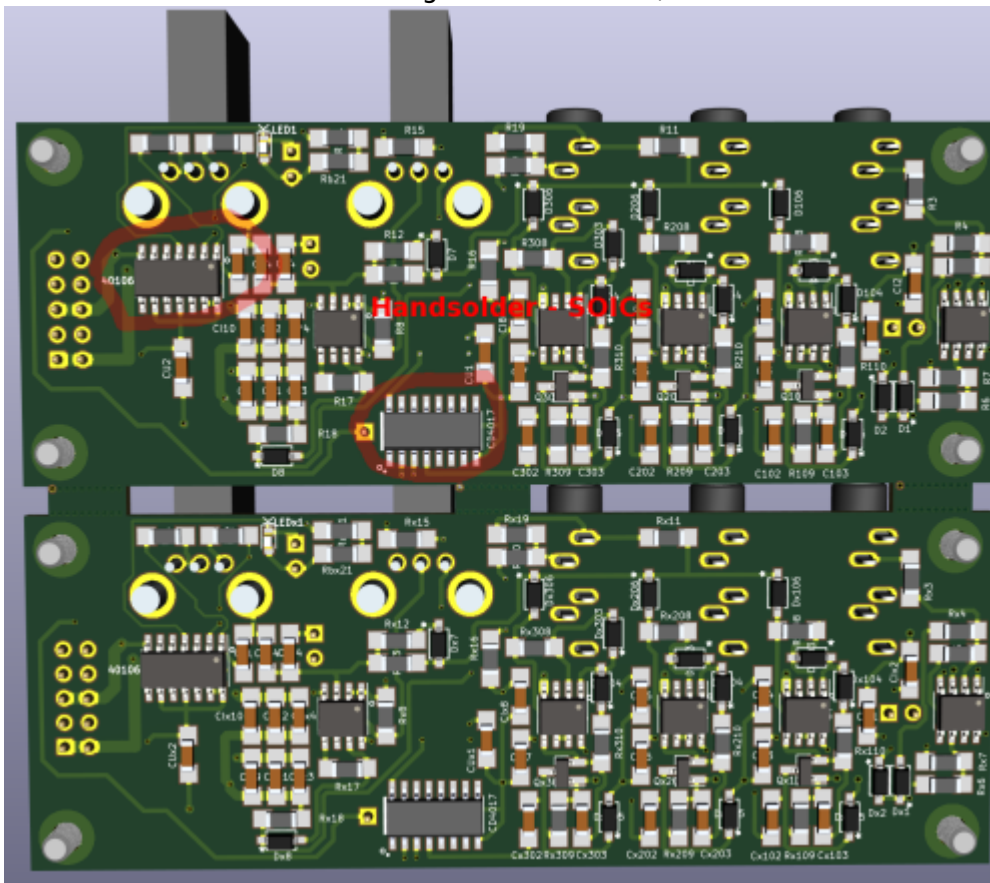

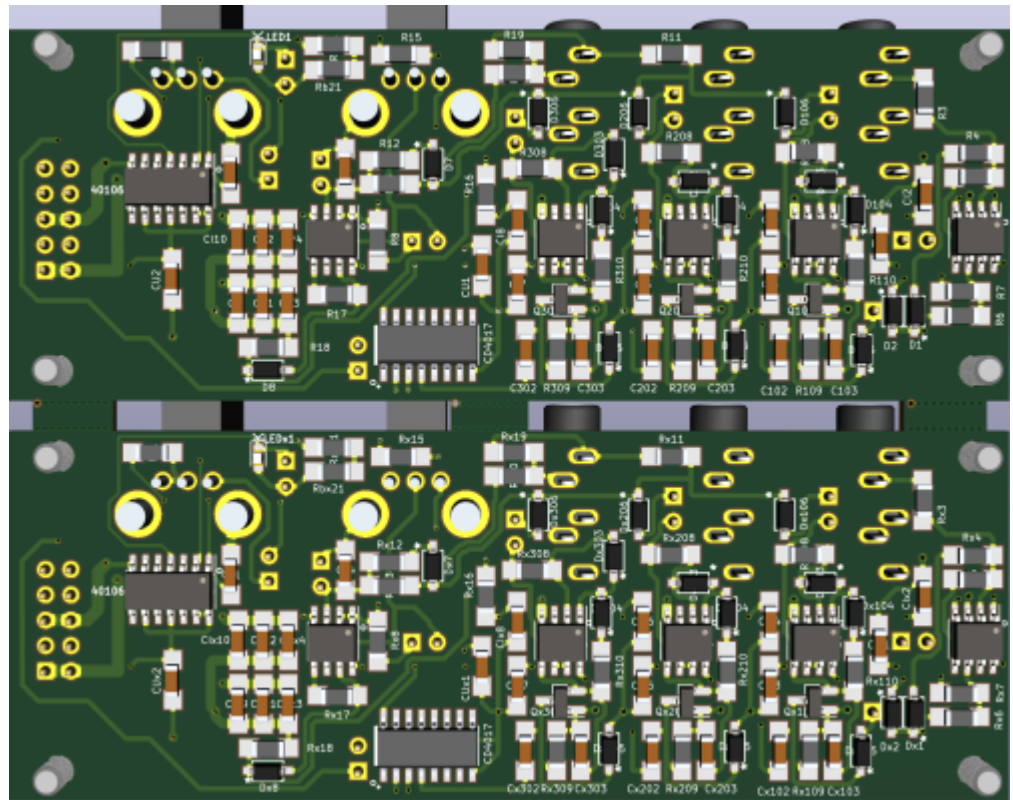

the actual Picture is this

Overall Material Costs

PCB:**42,44€** + MouserParts: **69,83** = 111,46€ / **10** PCBs = **11,14€ a PCB**
(where half off work is done by pick and place machine!)

Kicad Files & Production Files

V1. from 05.01.2021 [env-follower.zip](#)

Schematic, Board, Gerber, Pick and Place and Booms, ready for Pick and Place!

—at the moment untestet, since i order the project just now!

as Example what you see if you got thru the ordering process:

2021-01-06 | W202101



SMT Assembly
 Order #: 23438-2436262A
 Build Time: 1 day
 5 pcs \$28.36
[Product Details](#)

bom-LCSC.xls
 cpl.xls
[Reviewing](#)

File review will be completed in 10-60 mins when business hours.

Merchandise Total: \$30.87
 Shipping Charge: \$18.71
 Order Total: \$49.58

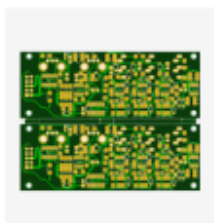

PCB Prototype
 Order #: 62A
 Build Time: 2-3 days
 5 pcs \$2.51
[Product Details](#)

follow_Y6
[Reviewing](#)

File review will be completed in 10-60 mins when business hours.



JiaLiChuang (HongKong)Co., Limited

Unit 21, 28/F, Metropole Square
 No.2 On Yiu Street, Shatin
 New Territories
 HONG KONG
 support@jlcpcb.com
 +86 755 23919769
 JLCPCB.COM

Invoice No:	
Invoice Date:	06/01/2021
Batch No.:	W202101

Ship To:
 michael sigl
 AUSTRIA
 Email: higgermair@gmail.com
 Tel: ++4370070879
 VAT No:

Billing To:
 michael sigl
 AUSTRIA
 Email: higgermair@gmail.com
 Tel: ++4370070879
 VAT No:

Description	HS Code	Order Number	QTY	Unit Price	Total
PCB Assembly	73145	23438	5	\$5.6720	\$28.36
PCB Samples	85340	Y6	5	\$0.5020	\$2.51

Subtotal: \$30.87
Shipping: \$18.71
Grand Total: \$49.58

Schematic

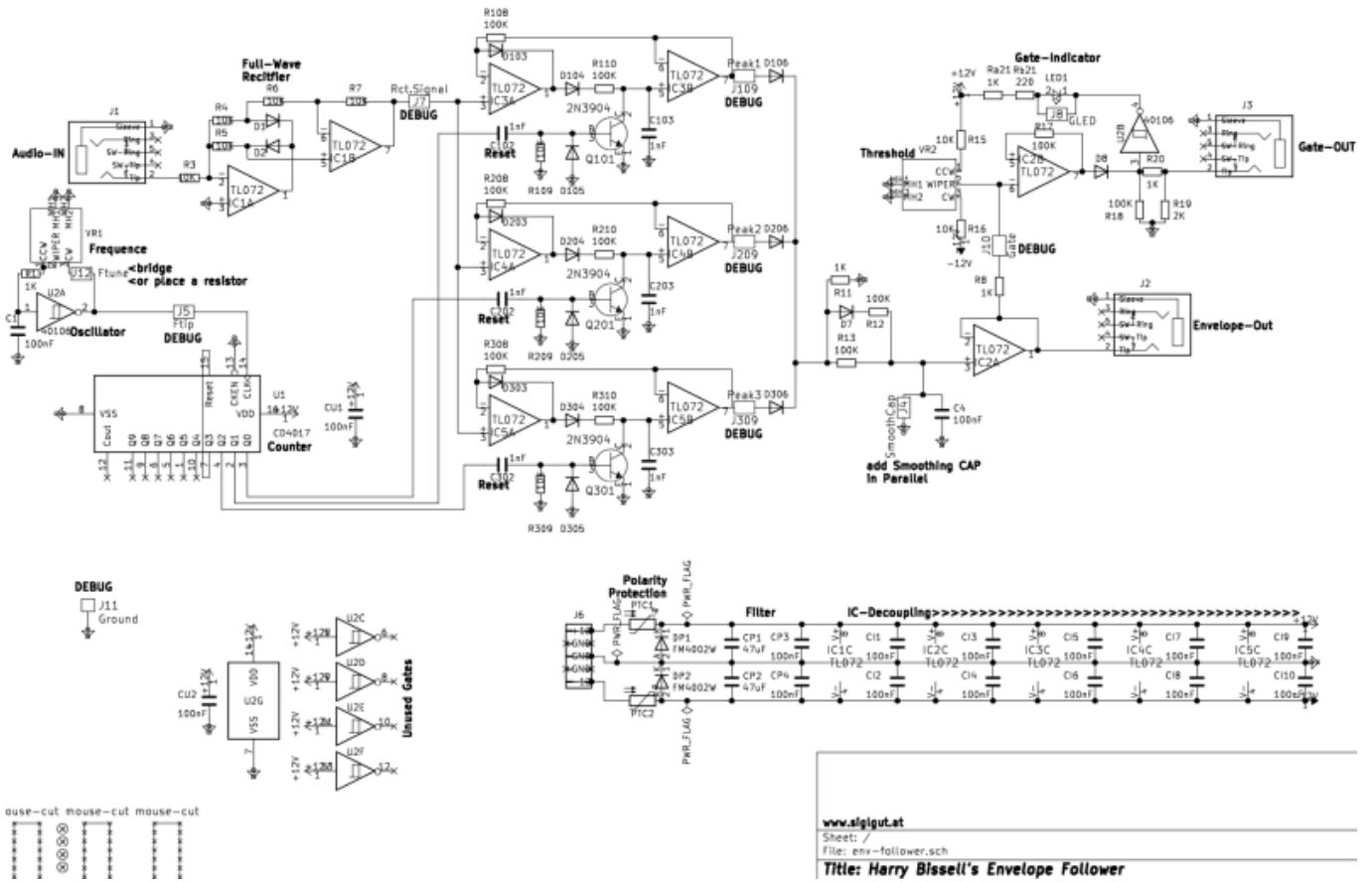

To Do

frontplate

Debugging First Version

experiment with the Smooting CAP: a Header is connected paralell to a integrated 100nF Cap, connect there a CAP to encrease the smoothing

experiment with the Frequency Pot: a lin10K + 1K internal Serial Resistor which gives a range of 1K-12K - i also made a Header here, which you can bridge then you have 1-12K, or you put a resistor there for example a 5K, then you will get a range from 6-16K...

I addet some Jumpers to break the circuit for debugging or measurement

Modding **Headers/Jumpers:**

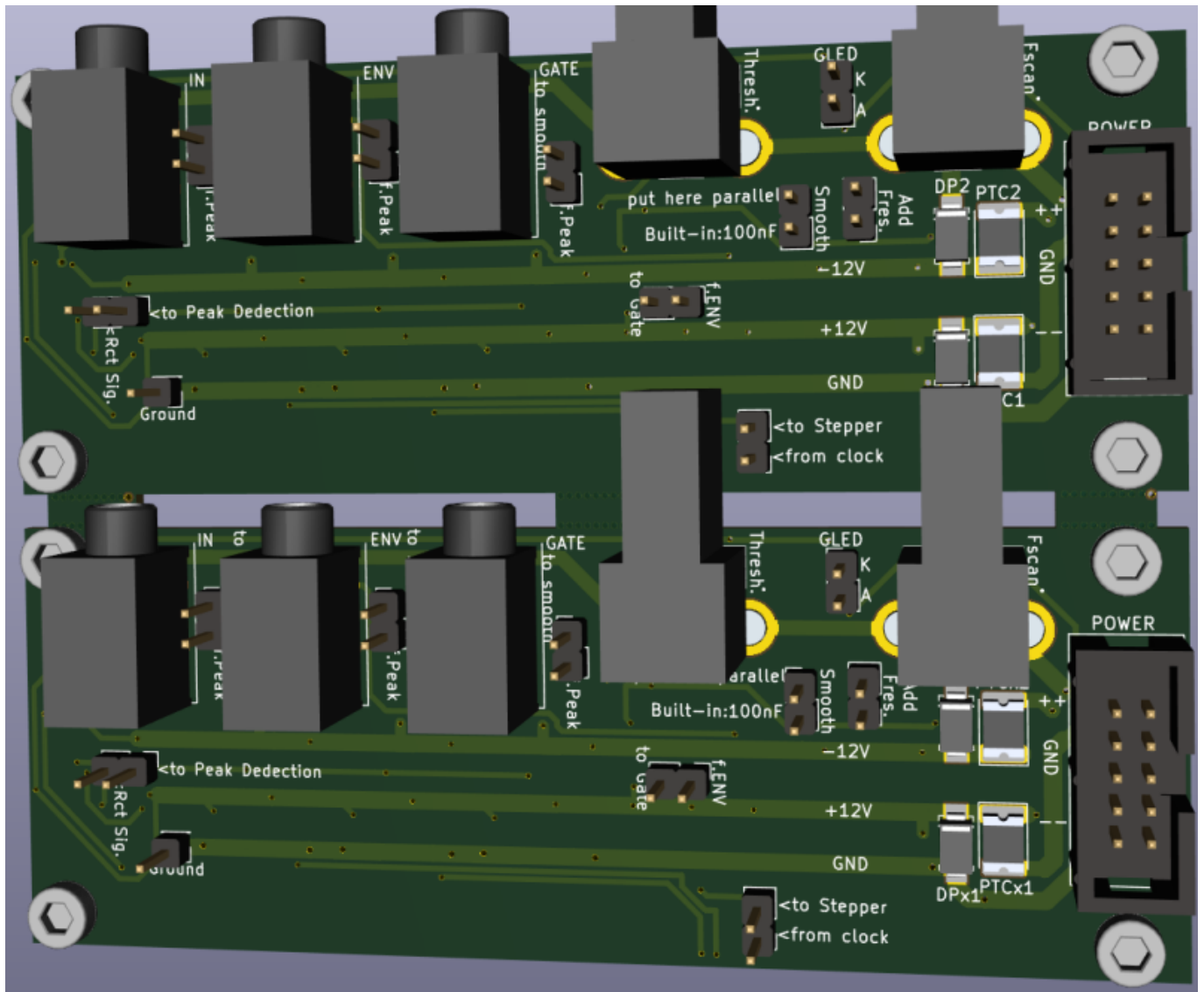

Resources

[muffwiggler-topic](#)
[modified-schematic](#)

[THT-PCB](#)

[THT-PCB-Schematic-BUT Attention it is not correct!](#)

[THT-PCB-BOM](#)

[Haralds-Hi-Clock-Measurements](#)

I give this links because it is the source: but i cant recommend that forum! (deletes of posts, shitstorm, non constructive posts...)

Community users working on it

- **Phatline** = Programming, Documentation...

Just let a Private message on the forum to user already involved.

I have ProtoBoards here - i test one, and if it works, i can share them for Beta Testing-if you pay the

postage

From:
<https://midibox.org/dokuwiki/> - **MIDIbox**

Permanent link:
<https://midibox.org/dokuwiki/doku.php?id=envelope-follower-bissel-based&rev=1609887678>

Last update: **2021/01/05 23:01**

