

SD Card Module

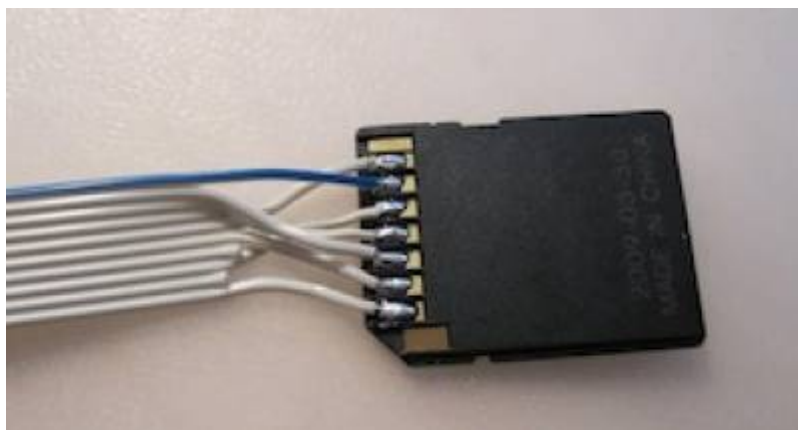

Interconnection

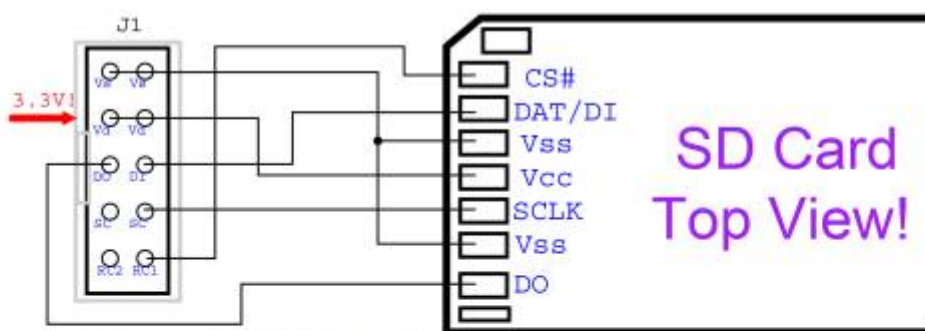

Note: DO connected to SI of Core Module
 DI connected to SO of Core Module
 S stands for "Serial", not "Slave"

Direct Connections are only possible with MBHP_CORE_STM32 (3.3V IO)
 PIC based MBHP_CORE (5.0V IO) requires additional resistors (voltage dividers)
 and a 3.3V Voltage Regulator

MIDIbox Hardware Platform
 MBHP_SDCARD
 (C) T. Klose 2009-02-24

STM32 Specific

The resistor array R30 of the MBHP_CORE_STM32 module shouldn't be connected when a SD Card is used, because pads are configured in Push-Pull mode at 3.3V. SD Card transfers could work unstable with these Pull-Up resistors!

From:
<https://midibox.org/dokuwiki/> - **MIDIbox**

Permanent link:
https://midibox.org/dokuwiki/doku.php?id=sd_card_module&rev=1467025207

Last update: **2016/06/27 11:00**



